

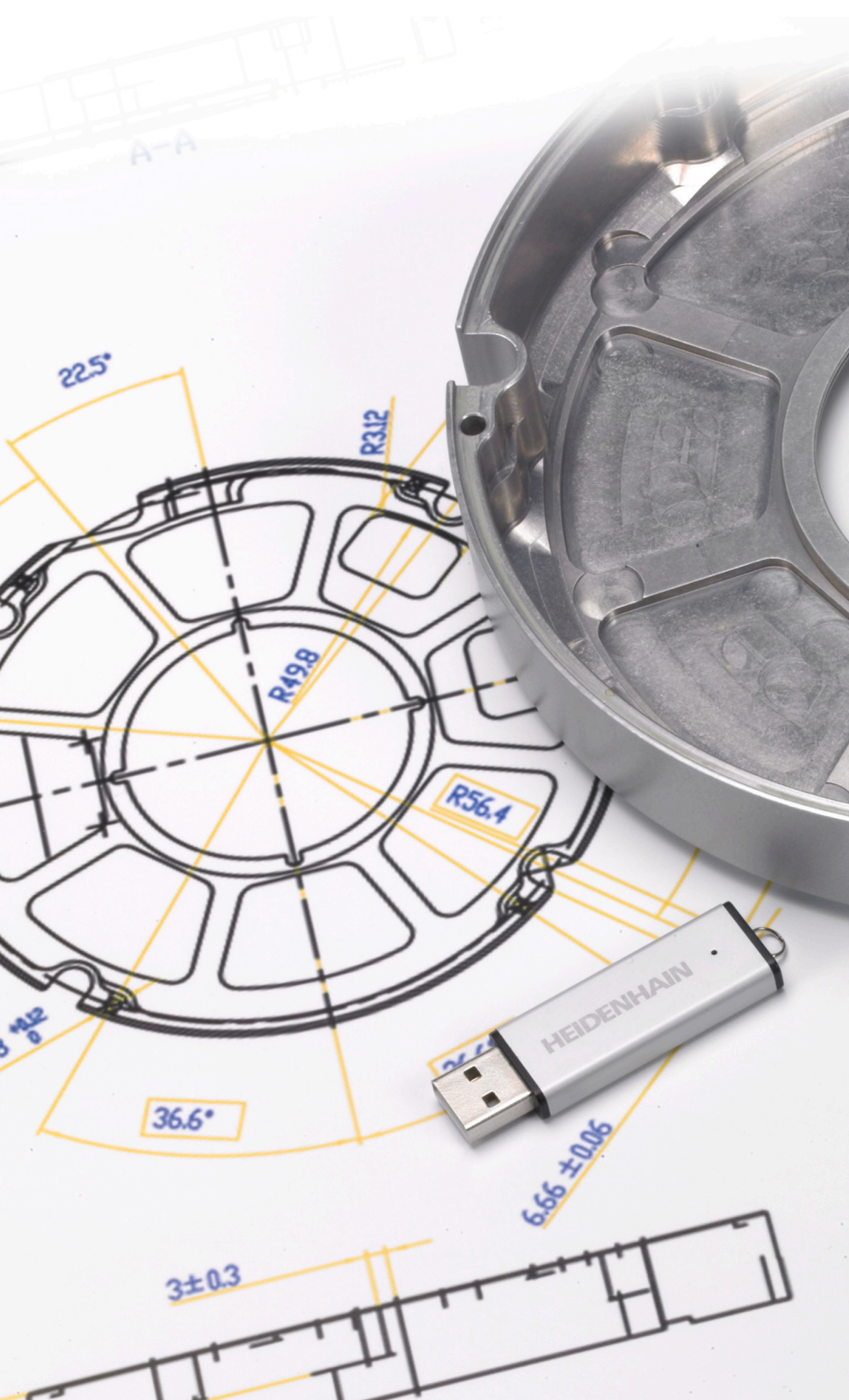

# HEIDENHAIN



## NC-Solutions

Conjunto de planos 13004

Español (es)  
6/2018

## 1 Conjunto de planos\_13004

### Lista de piezas Motor aire comprimido

#### Piezas de fabricación

Nº	Denominación	Material	Número de documento
1	Eje	CW508L	D1256768-00
1	Placa	ENAW 2007	D1256772-00
1	Pistones	CW508L	D1256799-00
1	Disco	CW508L	D1256806-00
1	Eje	CW508L	D1256807-00
1	Placa	ENAW 2007	D1256809-00
1	Carcasa	PMMA	D1256812-00
1	Placa	ENAW 2007	D1256815-00
1	Disco	CW508L	D1256823-00
1	Eje	CW508L	D1256826-00
1	Tapa de carcasa	PMMA	D1256827-00

#### Piezas estándar

Nº	Denominación	Norma	Advertencia
2	Tornillo de cabeza plana M4 x 18	DIN EN ISO 4762	Hexágono interior
4	Tornillo de cabeza plana M4 x 6	DIN EN ISO 4762	Hexágono interior
4	Tornillo avellanado M3 x 8	DIN EN ISO 7046-1	Hexágono interior
2	Tornillo prisionero M4 x 6	DIN EN 27434	Con punta
1	Pasador cilíndrico Ø3 x 12 mm	DIN EN ISO 8734	
1	Disco de seguridad Ø 3,2	DIN 6799-3,2	
1	Sellador (p.ej., silicona)		Hueco para la carcasa del motor

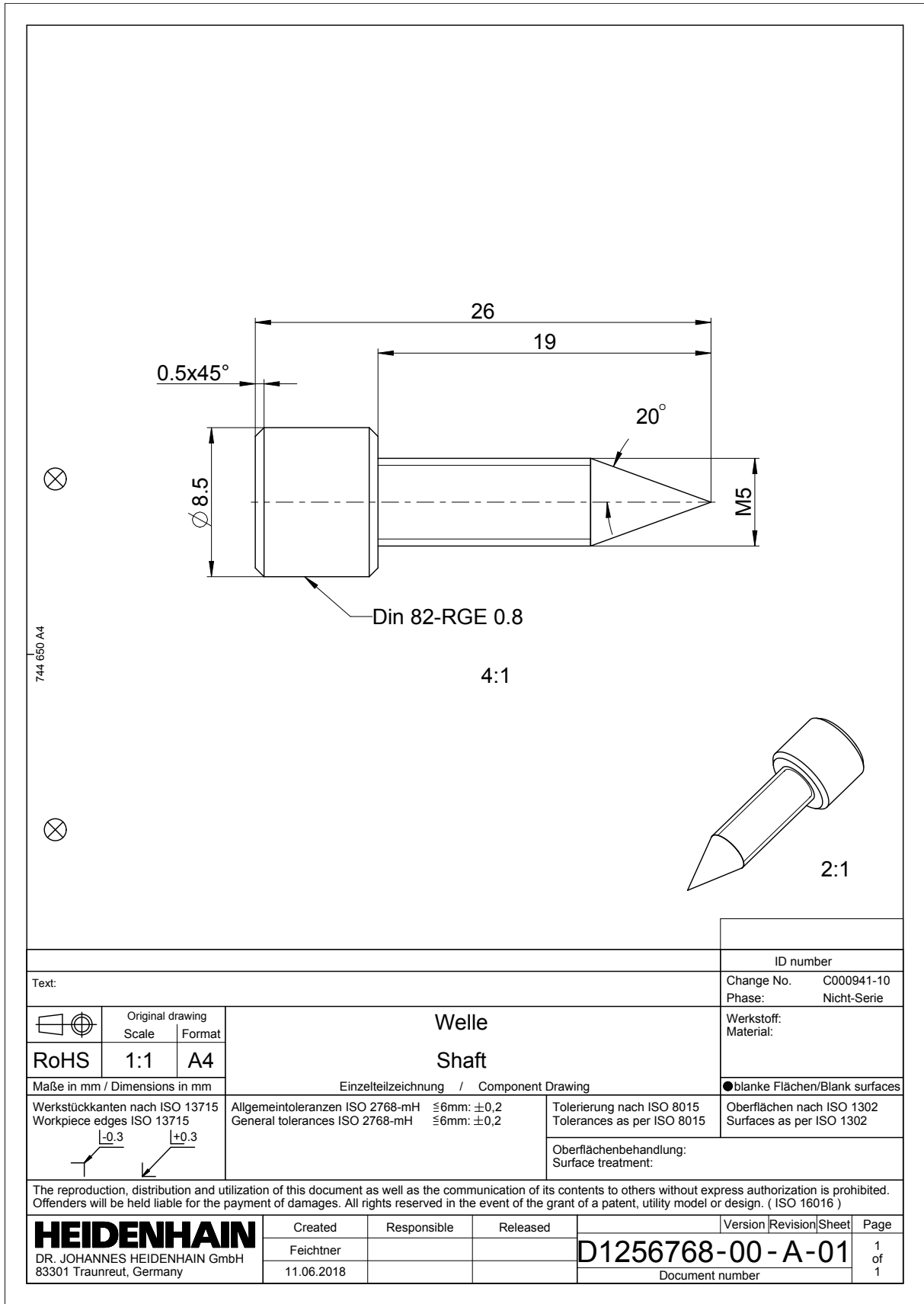

744 650 A4

Text:		ID number
Change No. C000941-10		Phase: Nicht-Serie
Werkstoff: Material:		
Maße in mm / Dimensions in mm		●blanke Flächen/Blank surfaces
Werkstückkanten nach ISO 13715 Workpiece edges ISO 13715		Tolerierung nach ISO 8015 Tolerances as per ISO 8015
Allgemeintoleranzen ISO 2768-mH $\leq 6\text{mm}$ : $\pm 0,2$ General tolerances ISO 2768-mH $\leq 6\text{mm}$ : $\pm 0,2$		Oberflächen nach ISO 1302 Surfaces as per ISO 1302
Oberflächenbehandlung: Surface treatment:		
The reproduction, distribution and utilization of this document as well as the communication of its contents to others without express authorization is prohibited. Offenders will be held liable for the payment of damages. All rights reserved in the event of the grant of a patent, utility model or design. ( ISO 16016 )		
<b>HEIDENHAIN</b> DR. JOHANNES HEIDENHAIN GmbH 83301 Traunreut, Germany	Created	Responsible
	Released	Version
Feichtner	11.06.2018	
D1256768-00 - A-01		Revision
Document number		Sheet
		Page
		1 of 1

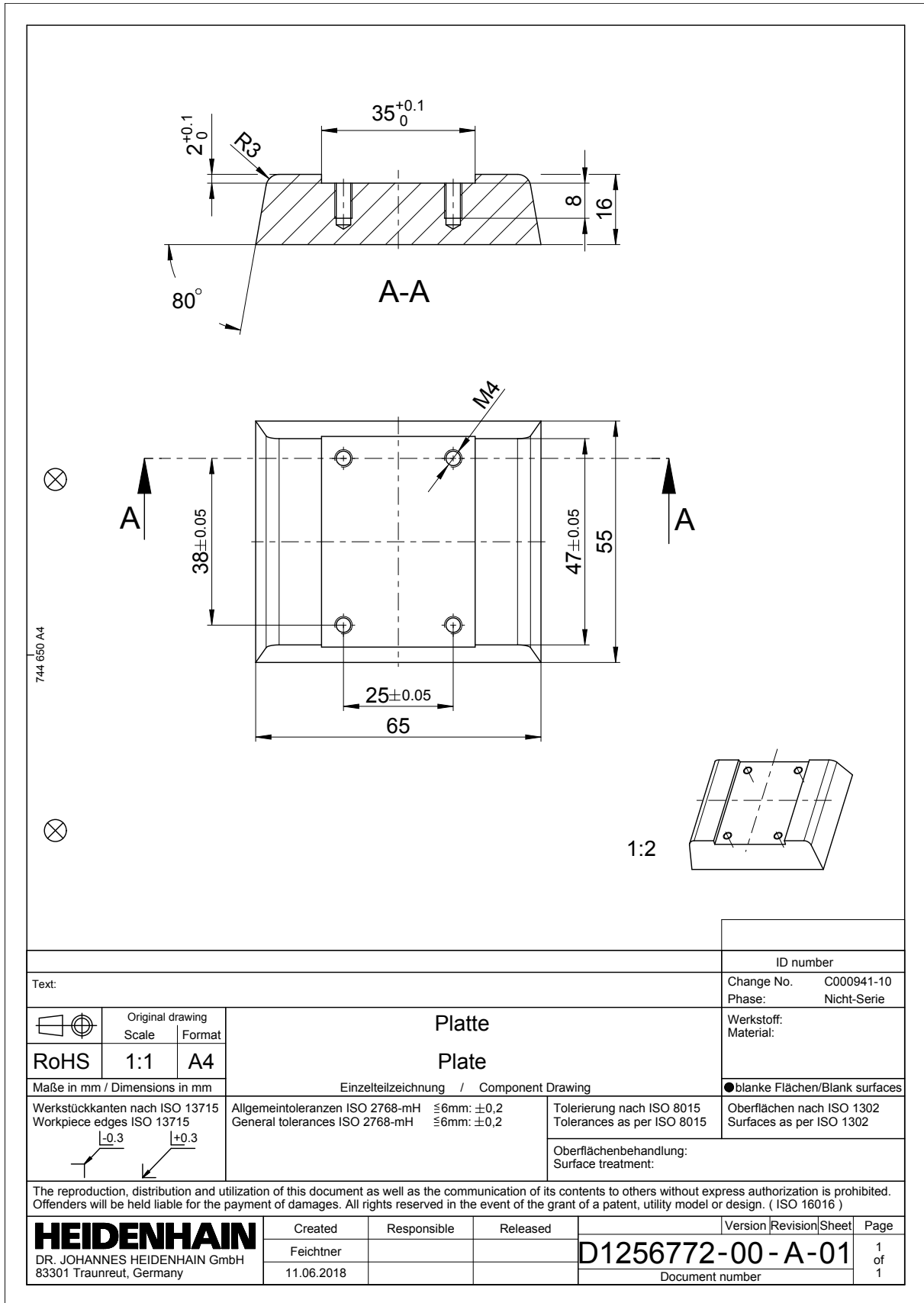

744 650 A4

Text:		ID number
Change No. C000941-10		Phase: Nicht-Serie
Werkstoff: Material:		
Maße in mm / Dimensions in mm		●blanke Flächen/Blank surfaces
Werkstückkanten nach ISO 13715 Workpiece edges ISO 13715	Allgemeintoleranzen ISO 2768-mH General tolerances ISO 2768-mH	Tolerierung nach ISO 8015 Tolerances as per ISO 8015
$\begin{matrix} \swarrow -0.3 \\ \searrow +0.3 \end{matrix}$	$\leq 6\text{mm}: \pm 0,2$ $\leq 6\text{mm}: \pm 0,2$	Oberflächen nach ISO 1302 Surfaces as per ISO 1302
The reproduction, distribution and utilization of this document as well as the communication of its contents to others without express authorization is prohibited. Offenders will be held liable for the payment of damages. All rights reserved in the event of the grant of a patent, utility model or design. ( ISO 16016 )		Oberflächenbehandlung: Surface treatment:
<b>HEIDENHAIN</b> DR. JOHANNES HEIDENHAIN GmbH 83301 Traunreut, Germany	Created	Version
	Responsible	Revision
Released	Sheet	Page
Feichtner	D1256772-00-A-01	
11.06.2018	Document number	
	1	of 1
	1	

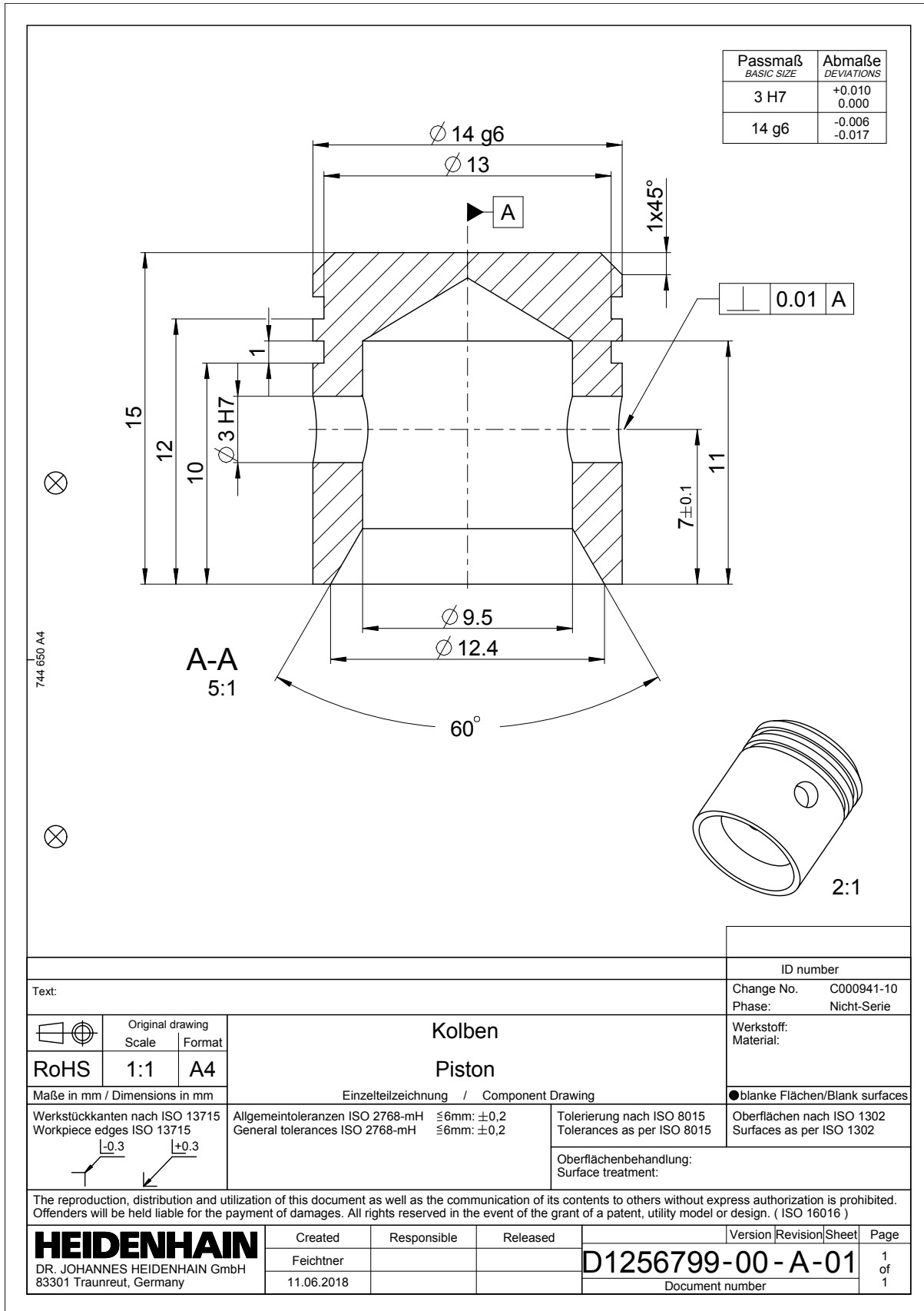

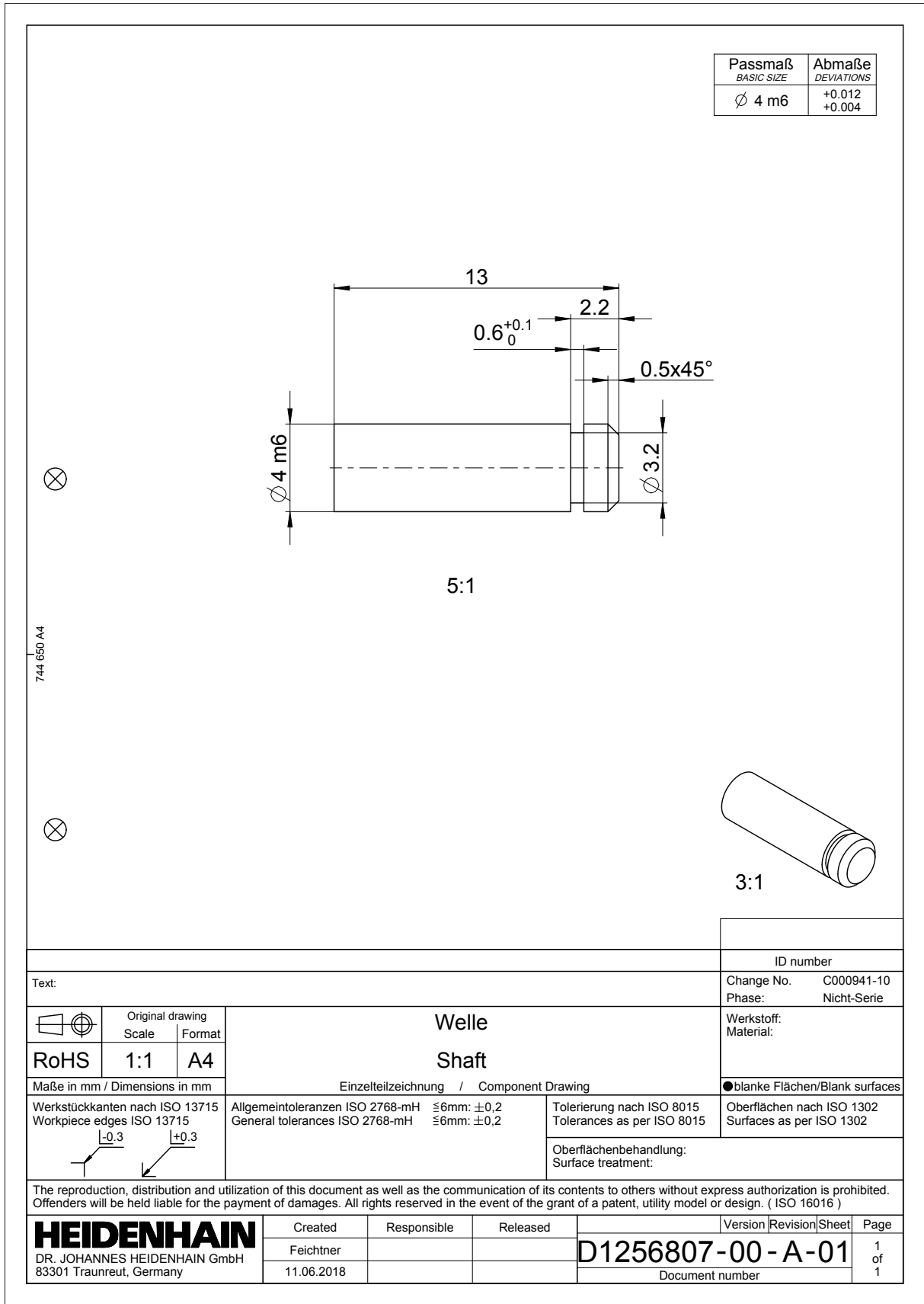

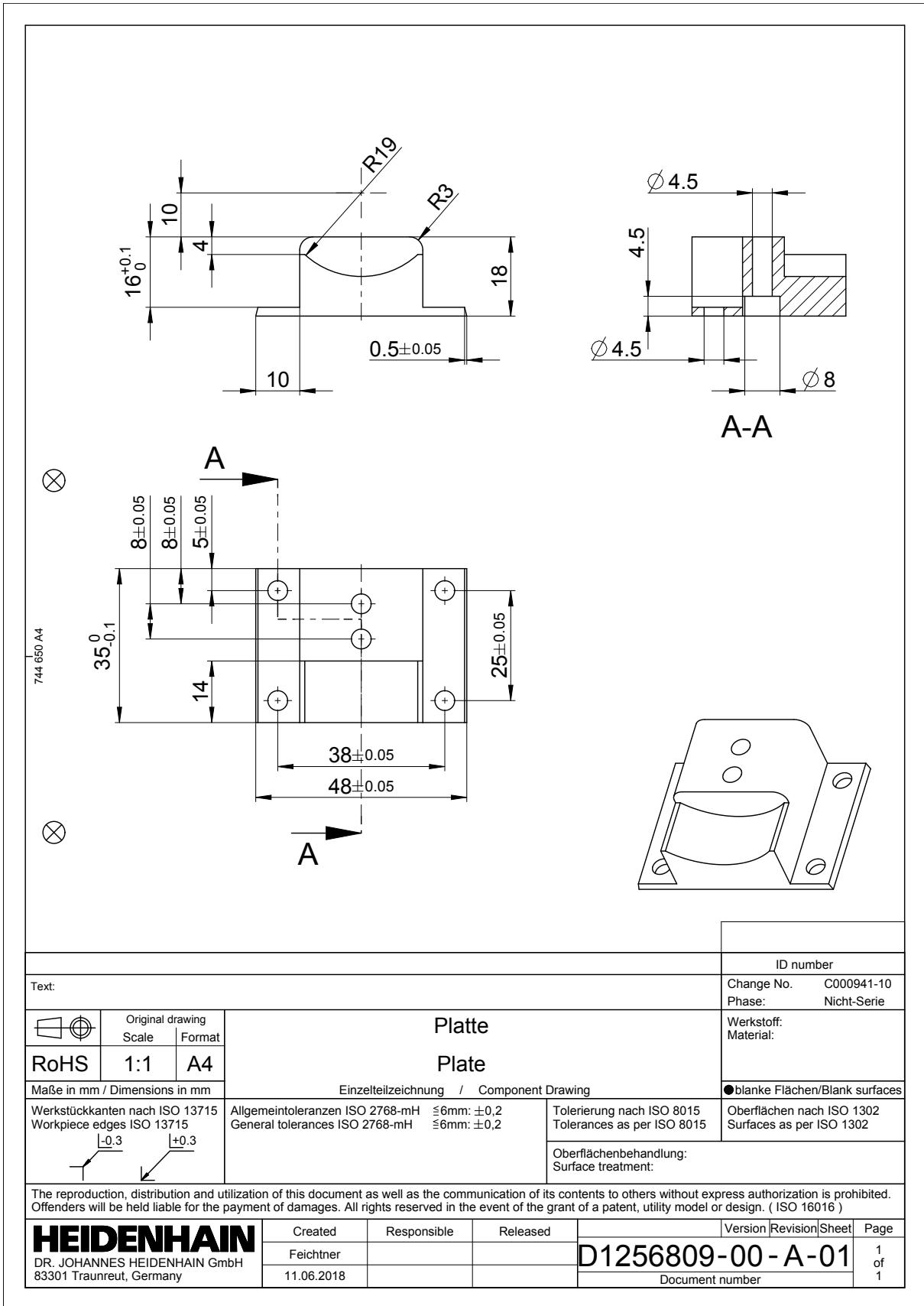

Text:		ID number																
		Change No. C000941-10																
		Phase: Nicht-Serie																
<table border="1"> <tr> <td></td> <td>Original drawing</td> <td colspan="2">Platte</td> </tr> <tr> <td>Scale</td> <td>Format</td> <td colspan="2">Plate</td> </tr> <tr> <td>RoHS</td> <td>1:1</td> <td colspan="2">Einzelteilzeichnung / Component Drawing</td> </tr> <tr> <td colspan="2">Maße in mm / Dimensions in mm</td> <td colspan="2">●blanke Flächen/Blank surfaces</td> </tr> </table>			Original drawing	Platte		Scale	Format	Plate		RoHS	1:1	Einzelteilzeichnung / Component Drawing		Maße in mm / Dimensions in mm		●blanke Flächen/Blank surfaces		Werkstoff: Material:
	Original drawing	Platte																
Scale	Format	Plate																
RoHS	1:1	Einzelteilzeichnung / Component Drawing																
Maße in mm / Dimensions in mm		●blanke Flächen/Blank surfaces																
<table border="1"> <tr> <td>Werkstückkanten nach ISO 13715 Workpiece edges ISO 13715</td> <td>Allgemeintoleranzen ISO 2768-mH General tolerances ISO 2768-mH</td> <td>Tolerierung nach ISO 8015 Tolerances as per ISO 8015</td> <td>Oberflächen nach ISO 1302 Surfaces as per ISO 1302</td> </tr> <tr> <td></td> <td>≤6mm: ±0,2 ≤6mm: ±0,2</td> <td colspan="2">Oberflächenbehandlung: Surface treatment:</td> </tr> </table>		Werkstückkanten nach ISO 13715 Workpiece edges ISO 13715	Allgemeintoleranzen ISO 2768-mH General tolerances ISO 2768-mH	Tolerierung nach ISO 8015 Tolerances as per ISO 8015	Oberflächen nach ISO 1302 Surfaces as per ISO 1302		≤6mm: ±0,2 ≤6mm: ±0,2	Oberflächenbehandlung: Surface treatment:										
Werkstückkanten nach ISO 13715 Workpiece edges ISO 13715	Allgemeintoleranzen ISO 2768-mH General tolerances ISO 2768-mH	Tolerierung nach ISO 8015 Tolerances as per ISO 8015	Oberflächen nach ISO 1302 Surfaces as per ISO 1302															
	≤6mm: ±0,2 ≤6mm: ±0,2	Oberflächenbehandlung: Surface treatment:																
<p>The reproduction, distribution and utilization of this document as well as the communication of its contents to others without express authorization is prohibited. Offenders will be held liable for the payment of damages. All rights reserved in the event of the grant of a patent, utility model or design. ( ISO 16016 )</p>																		
<b>HEIDENHAIN</b> DR. JOHANNES HEIDENHAIN GmbH 83301 Traunreut, Germany		Created Feichtner 11.06.2018	Responsible Released															
		Version Revision Sheet Page D1256809-00 - A-01 1 of 1 Document number																

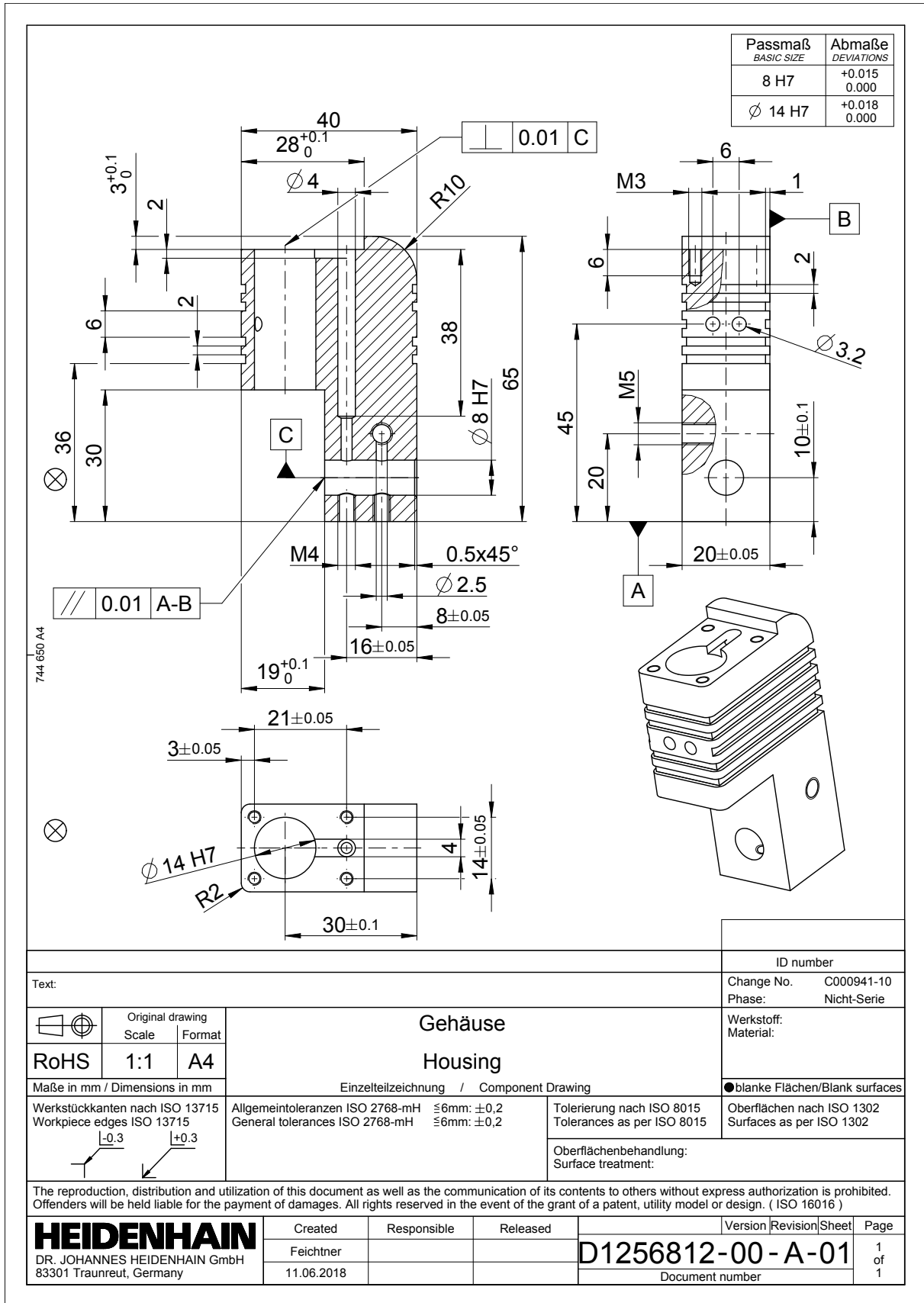

Text:		ID number																						
Change No. C000941-10		Phase: Nicht-Serie																						
Werkstoff: Material:		●blanke Flächen/Blank surfaces																						
<table border="1"> <tr> <th>Original drawing</th> <th>Scale</th> <th>Format</th> </tr> <tr> <td></td> <td>1:1</td> <td>A4</td> </tr> </table>		Original drawing	Scale	Format		1:1	A4	<p><b>Gehäuse</b> <b>Housing</b></p> <p>Einzelteilzeichnung / Component Drawing</p>																
Original drawing	Scale	Format																						
	1:1	A4																						
Maße in mm / Dimensions in mm		Tolerierung nach ISO 8015 Tolerances as per ISO 8015																						
<p>Werkstückkanten nach ISO 13715 Workpiece edges ISO 13715</p> <p><math>\sqrt{\text{Ra}} -0.3</math>    <math>\sqrt{\text{Ra}} +0.3</math></p>		<p>Oberflächen nach ISO 1302 Surfaces as per ISO 1302</p> <p>Oberflächenbehandlung: Surface treatment:</p>																						
<p>The reproduction, distribution and utilization of this document as well as the communication of its contents to others without express authorization is prohibited. Offenders will be held liable for the payment of damages. All rights reserved in the event of the grant of a patent, utility model or design. ( ISO 16016 )</p>																								
<p><b>HEIDENHAIN</b> DR. JOHANNES HEIDENHAIN GmbH 83301 Traunreut, Germany</p>		<table border="1"> <tr> <th>Created</th> <th>Responsible</th> <th>Released</th> </tr> <tr> <td>Feichtner</td> <td></td> <td></td> </tr> <tr> <td>11.06.2018</td> <td></td> <td></td> </tr> </table>	Created	Responsible	Released	Feichtner			11.06.2018			<table border="1"> <tr> <th>Version</th> <th>Revision</th> <th>Sheet</th> <th>Page</th> </tr> <tr> <td colspan="3">D1256812-00-A-01</td> <td>1 of 1</td> </tr> <tr> <td colspan="4">Document number</td> </tr> </table>	Version	Revision	Sheet	Page	D1256812-00-A-01			1 of 1	Document number			
Created	Responsible	Released																						
Feichtner																								
11.06.2018																								
Version	Revision	Sheet	Page																					
D1256812-00-A-01			1 of 1																					
Document number																								



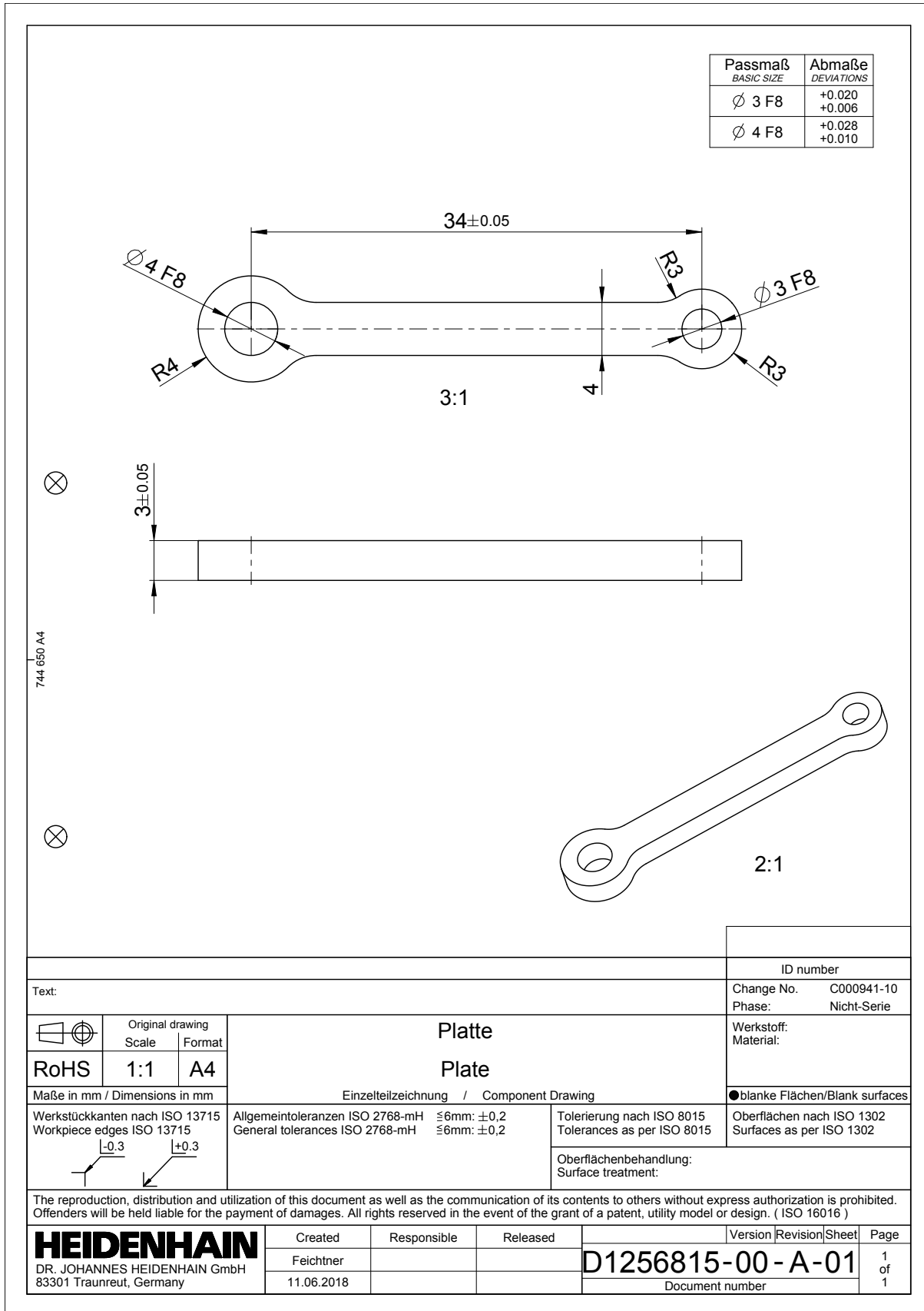

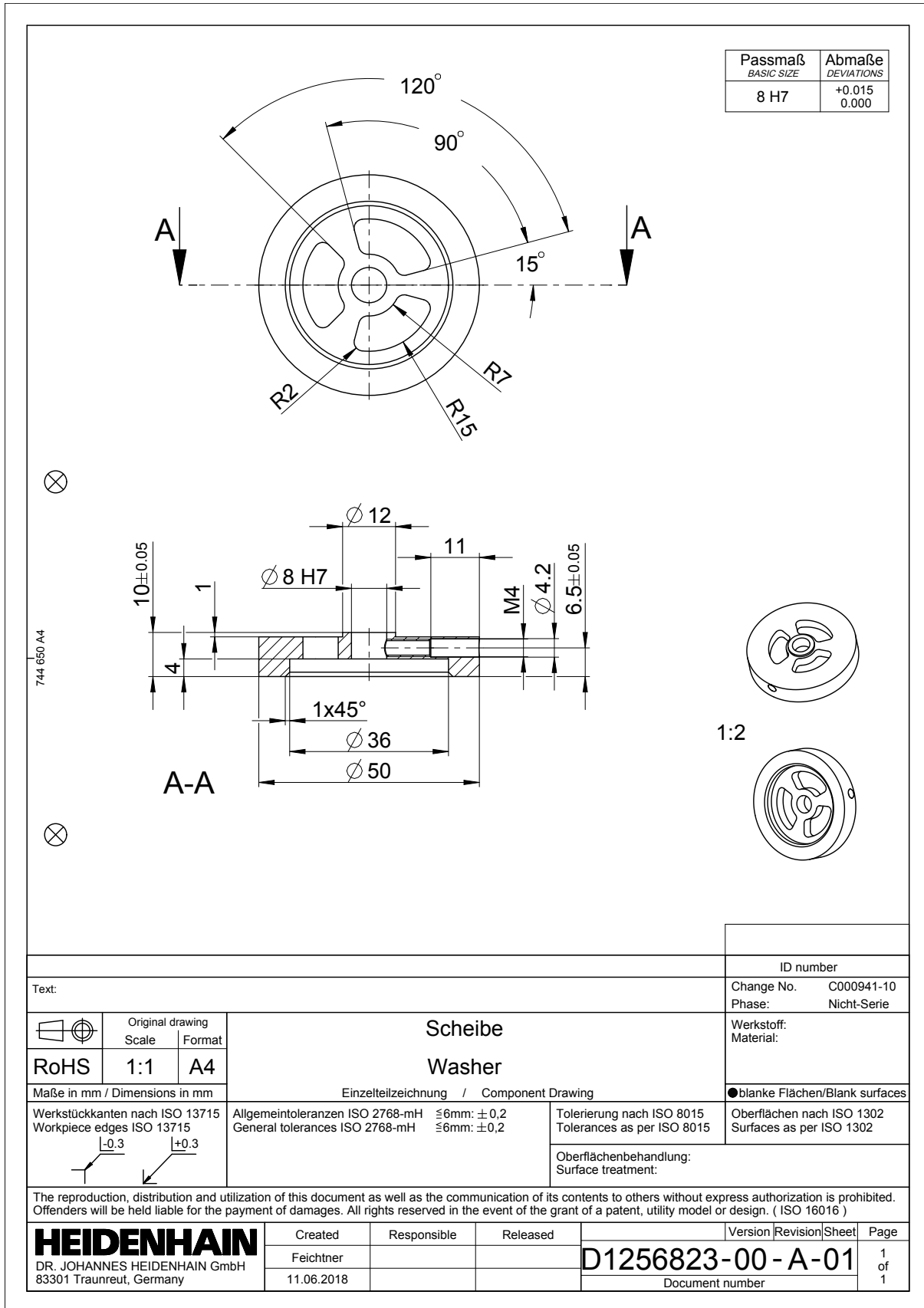

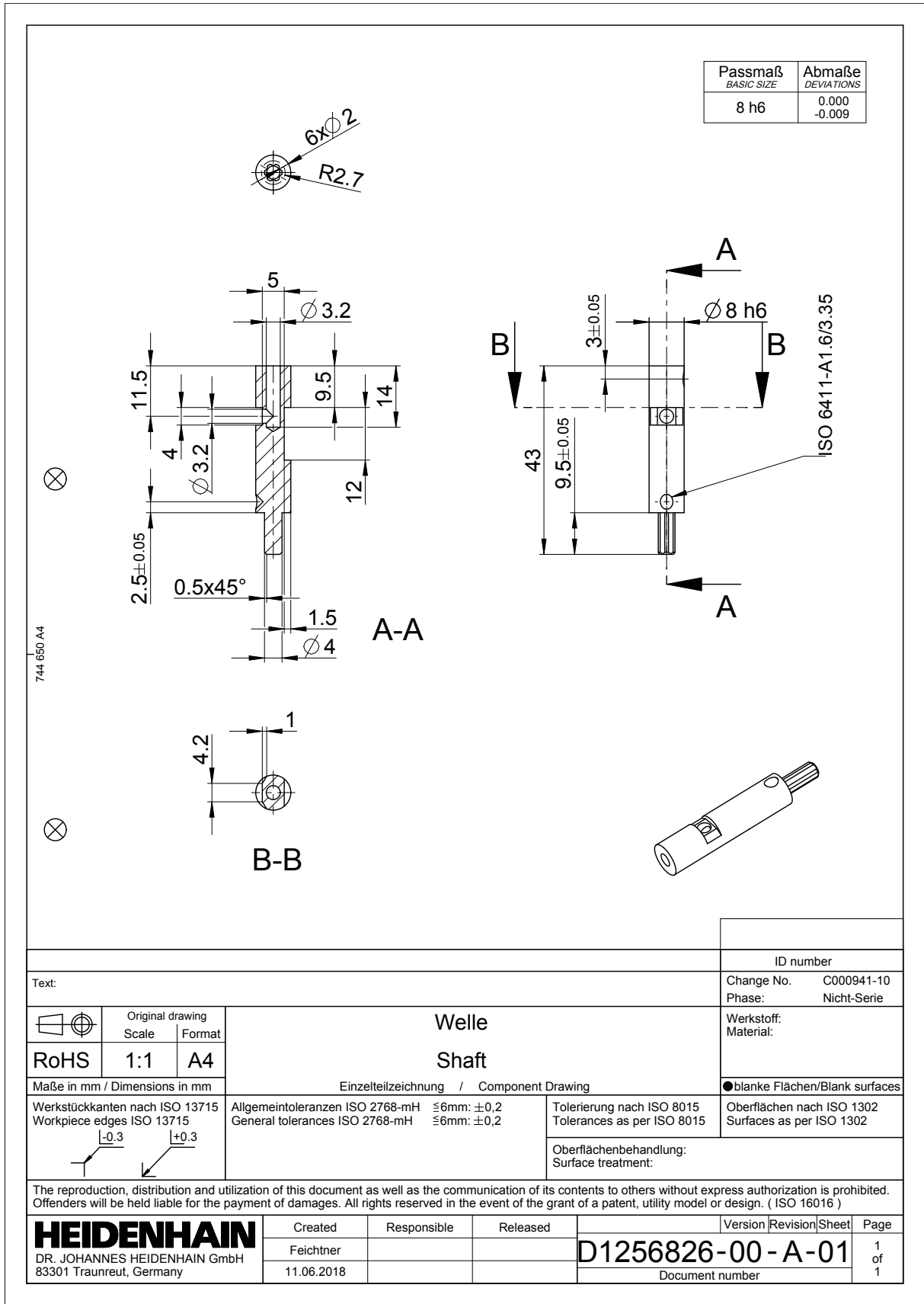

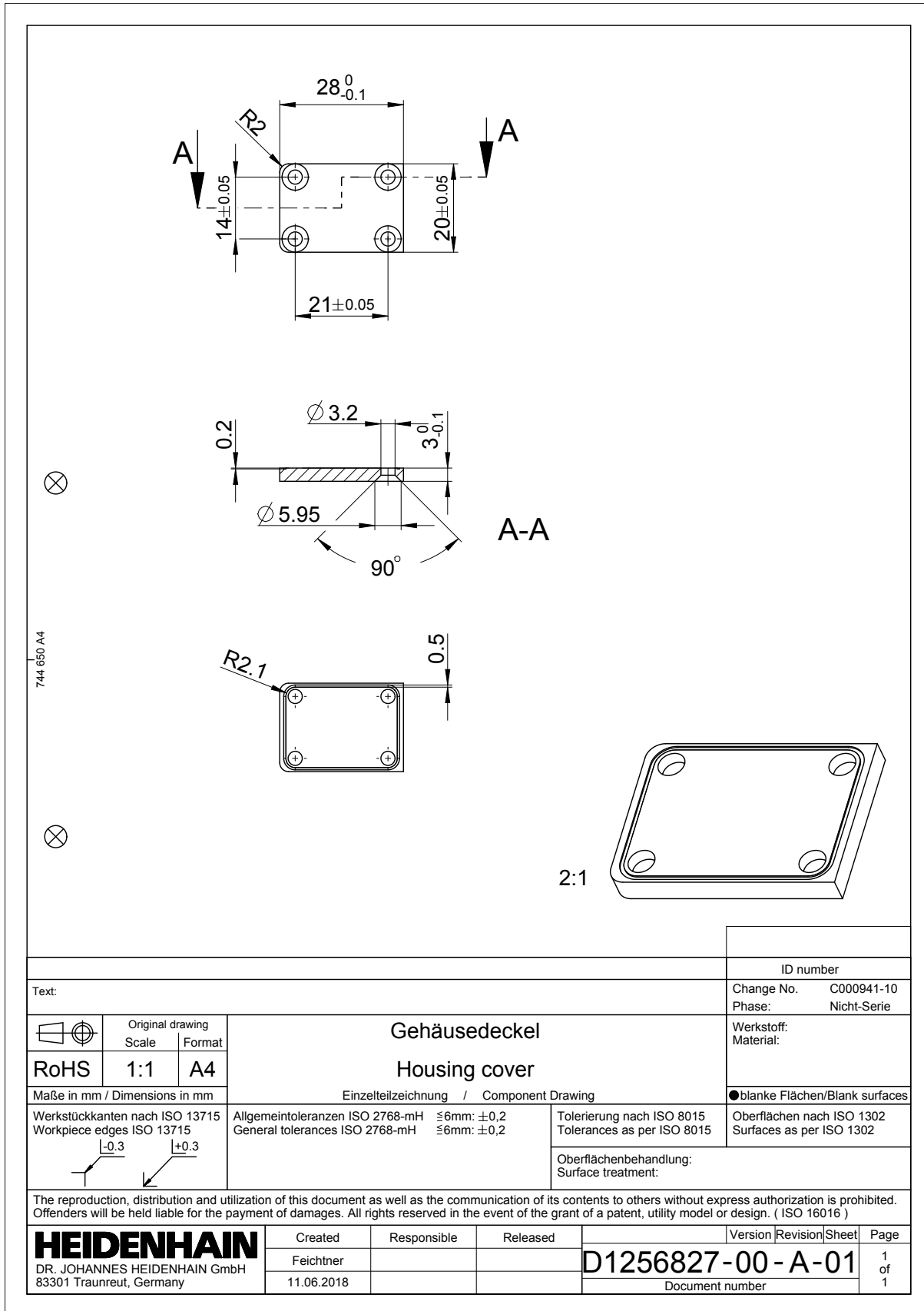

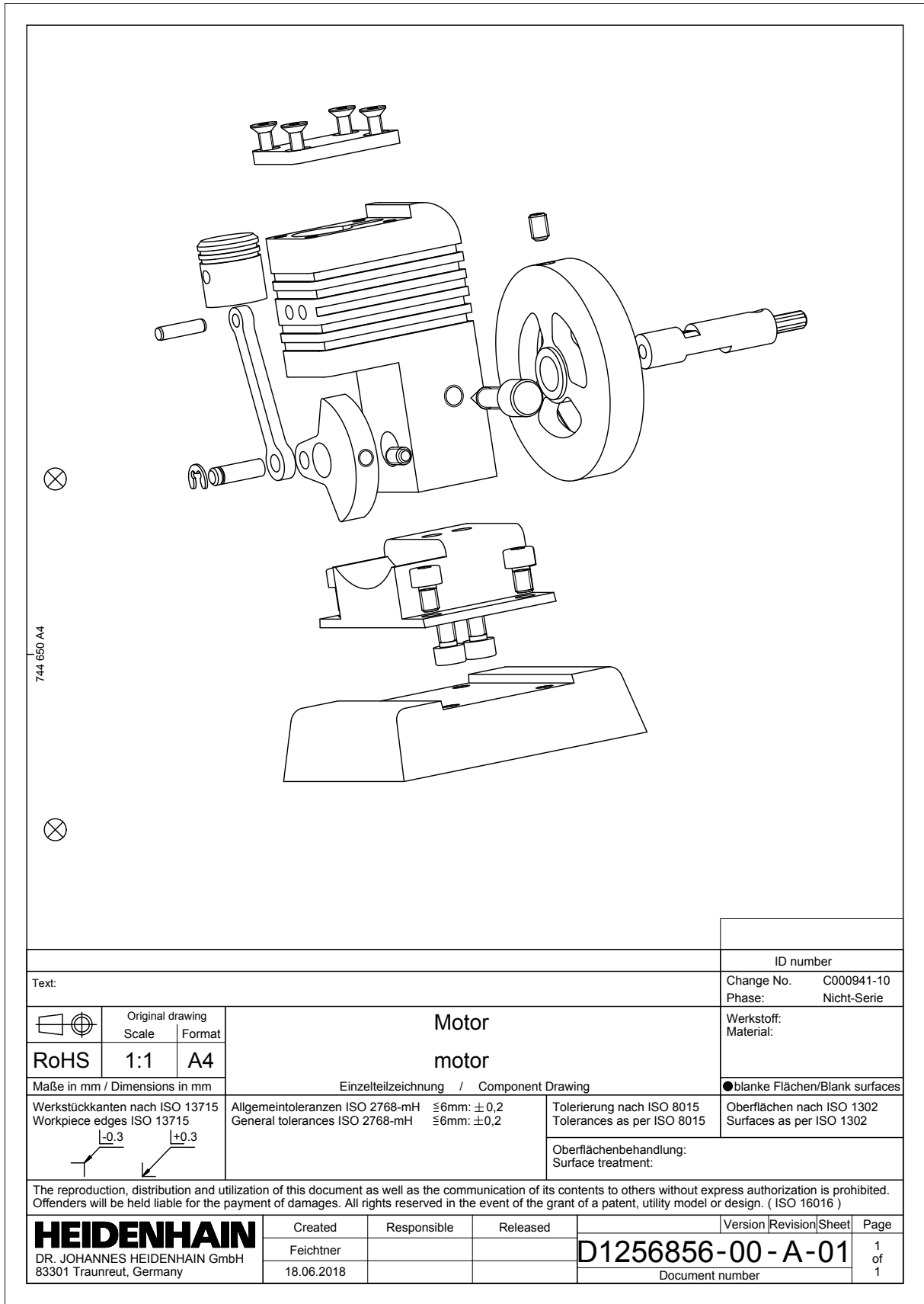

744 650 A4

Text:		ID number											
		Change No. C000941-10											
		Phase: Nicht-Serie											
<table border="1"> <tr> <td></td> <td>Original drawing</td> <td colspan="2" rowspan="2" style="text-align: center;"><b>Motor</b></td> </tr> <tr> <td></td> <td>Scale   Format</td> </tr> <tr> <td>RoHS</td> <td>1:1   A4</td> <td colspan="2" style="text-align: center;"><b>motor</b></td> </tr> </table>			Original drawing	<b>Motor</b>			Scale   Format	RoHS	1:1   A4	<b>motor</b>		Werkstoff: Material:	
	Original drawing	<b>Motor</b>											
	Scale   Format												
RoHS	1:1   A4	<b>motor</b>											
Maße in mm / Dimensions in mm		Einzelteilzeichnung / Component Drawing											
Werkstückkanten nach ISO 13715 Workpiece edges ISO 13715 		Allgmeintoleranzen ISO 2768-mH $\leq 6\text{mm}$ : $\pm 0,2$ General tolerances ISO 2768-mH $\leq 6\text{mm}$ : $\pm 0,2$	Tolerierung nach ISO 8015 Tolerances as per ISO 8015  Oberflächenbehandlung: Surface treatment:										
		●blanke Flächen/Blank surfaces											
The reproduction, distribution and utilization of this document as well as the communication of its contents to others without express authorization is prohibited. Offenders will be held liable for the payment of damages. All rights reserved in the event of the grant of a patent, utility model or design. ( ISO 16016 )													
<b>HEIDENHAIN</b> DR. JOHANNES HEIDENHAIN GmbH 83301 Traunreut, Germany	Created	Responsible	Released										
	Feichtner												
	18.06.2018												
		<b>D1256856-00 - A-01</b>											
		Document number											
		Version	Revision   Sheet   Page										
			1 of 1										

